

# General Packaging

*FX Series — Sloped*



## **General Packaging (FX) Frame Series**

Cerified to MIL-STD 910D (Shock)

MIL-STD 810E (Vibration)

EIA-STD 310D

# GENERAL PACKAGING INTERIOR



Frame design provides optimal static (3,500 lbs.) load rating.



Four separate 14 ga. (.074) main channels, each with 3 forms, provide a rugged top frame assembly. Seam welded corners (heliarc) are reinforced by formed 12 ga. (.104) gusseting. Gussets also serve as built-in receptacles for lift-eye bolts.



Mounting channels are fully adjustable (front to rear) and available in punched and tapped versions (for #10-32 & #12-24 equipment thread sizes). Reducer mounting channels are also available in 24" to 19" panel opening width.

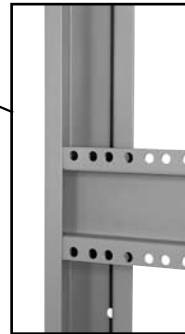

14 ga. vertical and side strut channels, each containing 4 forms are interwelded to dual return flanges. Vertical frame channels also provide direct floor bearing support.



Frame base assembly, with 3 forms on side struts and 2 forms on the front & rear crossies, are seam welded to the 4 main vertical channels. Formed 12 ga. gussets, spot welded to frame base corners for added strength also serve as caster brackets.

## General Packaging Frame Sizes

- 6 Vertical Panel Openings (21", 31", 42", 52", 61", 70" & 78")
- 2 Horizontal Panel Openings (19" & 24")
- 3 Overall Depths (25.50", 30" & 36")

# GENERAL PACKAGING EXTERIOR



Available in 10 standard colors, 2 finishes - textured or smooth. See IMS/AMCO Color Selection Chart.



Top Panels are available in solid, louvered, perforated and with 10" fans. IMS can provide top panels with cable egress, DC fans or other custom designs.



Side Panels feature a 5/8" width and are available in solid or louvered, and with bolt-on or lift-off features for easy access.



A variety of door options are available - solid, louvered and Plexiglas. Keyed locks are included on all doors. Enclosure panels are also available - as an option - to fill open RU in your cabinets panel opening space. (1RU to 21RU)



Cabinets easily join together with standard hardware to construct multi-bay consoles without any additional resources. Optional 30° and 45° pie sections are available for curved design configurations. IMS can also provide writing surfaces for workstation design requirements.

# GENERAL PACKAGING

FX Sloped Series - Vertical Frame Dimensions

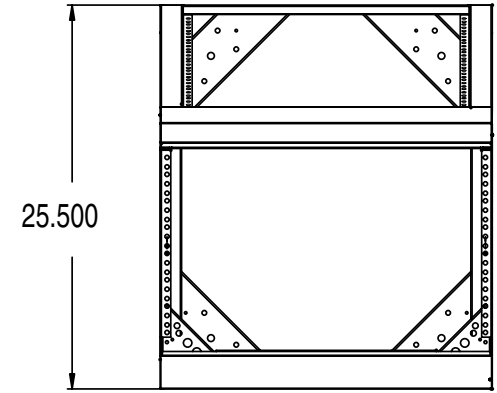
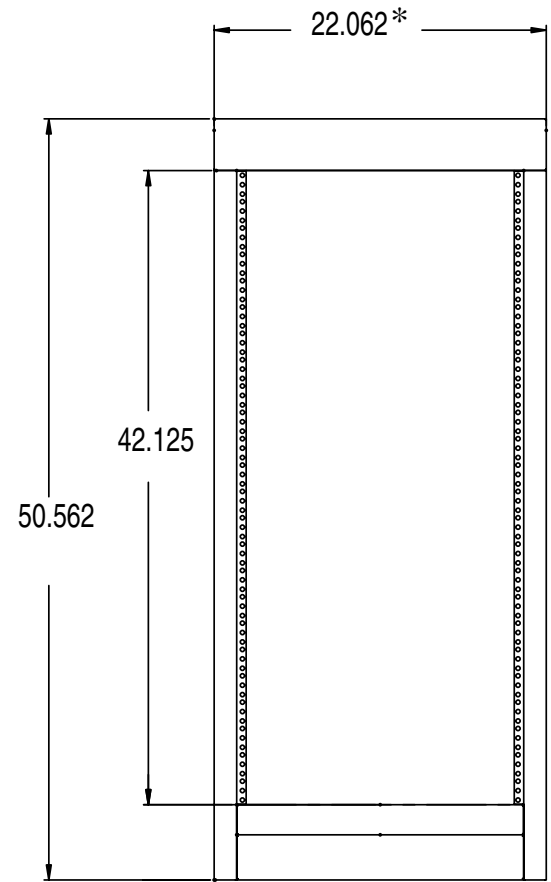
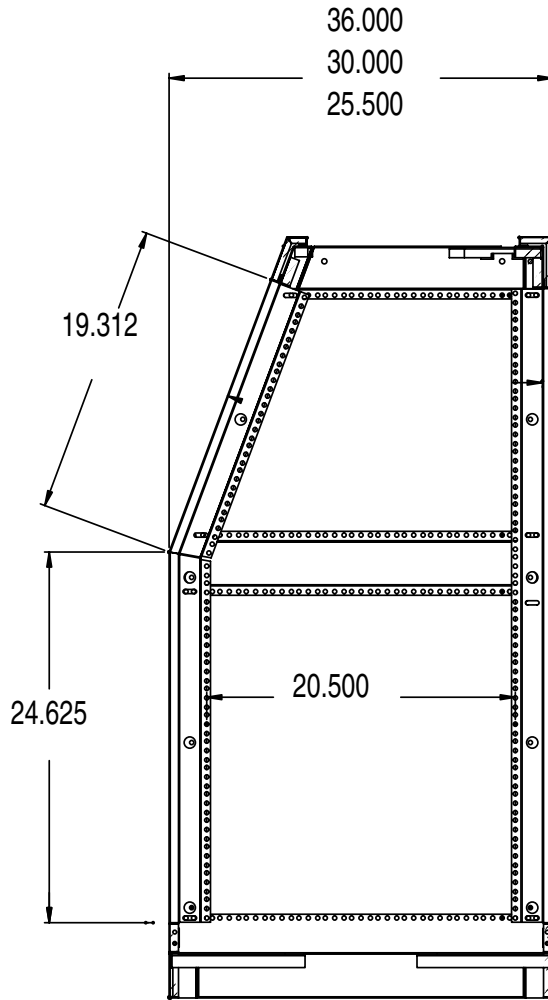
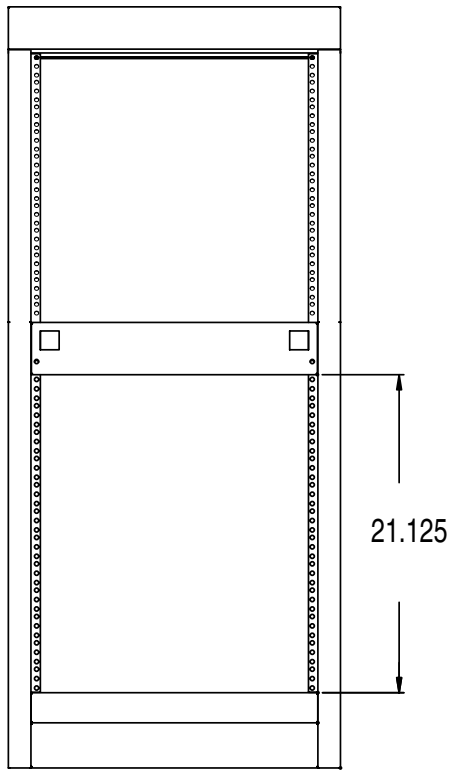

\*Note: For 24" panel width add 5.00" to the 19" panel width. Frame includes 2 top and base cowlings, 3 sets of MX mounting channels and 4 leg levelers.